



SHG ULTRA LOW PROFILE TROLLEY HOIST 0.5t~20t

- Combination hoist and trolley offer ultra-low headroom
- 0.5t ~ 20 ton capacity
- Load chain & hand chain is corrosion resistant
- Special production, specific to your application
- Wheels of the unit fit both I-beams and H- beams
- With anti-drop plates
- With overload protection safety device



Scan for Webpage,
User & Parts Manual



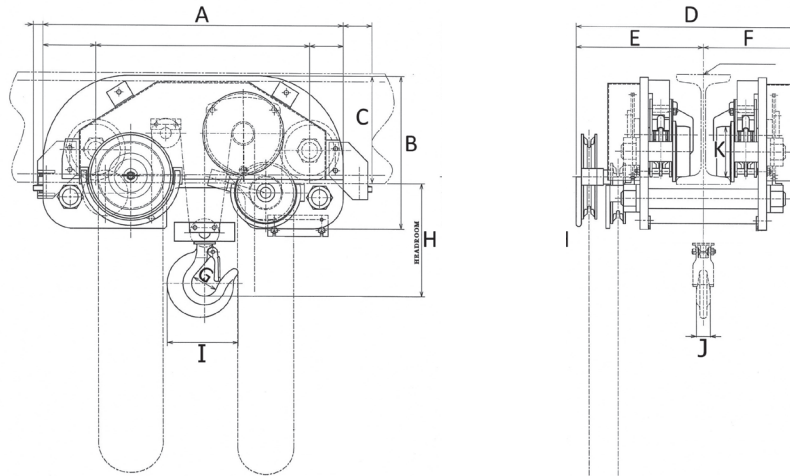

SPECIFICATIONS - SHG LOW PROFILE TROLLEY HOIST

Model	Capacity (metric ton)	Test load (metric ton)	Standard Lift (ft)	Dia. of Load Chain (mm) X Falls	Hand Effort to Lift (lbf)	Hand Effort to Traverse (lbf)	Headroom Dim. H (in)	I Beam Width Dim. W (in)
SHG-0.5	0.5	750kg	8	5x4	55	11	5.15	Manufactured to Specification
SHG-1	1	1.5	8	5x4	62	11	6.10	
SHG-1.6	1.6	2.4	8	5x4	84	9	7.08	
SHG-2	2	3	10	7.1x2	82	12	7.08	
SHG-3.1	3.15	4.8	10	7.1x4	84	18	7.91	
SHG-5	5	7.5	10	7.1x4	84	25	8.85	
SHG-10	10	12.5	10	9x4	88	60	10.23	
SHG-10B	10	12.5	10	9X4	88	60	11.40	
SHG-20	20	25	10	9x8	110	88	15.75	

DIMENSIONS (IN.) - SHG LOW PROFILE TROLLEY HOIST

Model	A	B	C	D	E	F	G	I	J	K	Unit Weight (lbs) with 10' Lift
SHG-0.5	26.8	11.0	7.0	19.6	11.4	8.2	1.6	7.2	0.5	3.2	132
SHG-1	26.8	11.0	7.0	19.6	11.4	8.2	1.9	3.9	0.7	3.2	135
SHG-1.6	26.8	11.0	7.1	19.6	11.4	8.2	2.6	5.4	1.0	3.9	154
SHG-2	26.8	11.0	7.1	19.6	11.4	8.2	2.6	5.4	1.0	3.9	154
SHG-3.1	30.5	13.7	8.9	20.3	11.6	8.7	2.4	6.5	1.2	4.5	331
SHG-5	32.7	13.7	8.9	21.5	12.0	9.4	2.8	6.1	1.4	4.9	551
SHG-10	36.9	16.5	11.0	22.6	12.7	9.9	3.3	9.0	1.8	6.2	772
SHG-20	45.2	19.6	13.1	24.2	13.5	10.7	4.4	12.1	2.7	7.8	1874

