



ELEPHANT INTEGRAL LUG MOUNT TROLLEY HOISTS, PUSH & GEARED

- Overload protection safety device
- Grade 105 corrosion resistant load chain, which adheres to the strict German DIN 5684 standard
- Zinc plated hand chain
- Double pawls supporting fail-safe brake mechanism
- Load sheave with roller bearing
- The tough reinforced gear case has four ribs and four knock pins, providing accurate gear centering and high mechanical efficiency
- Rolled edge hand wheel cover
- Heavy duty electrostatic powder coating
- Long life friction discs
- Suitable for operation within a -4° ~ 140° F temperature range
- Adjustable to fit various beam widths
- A solid carbon steel design
- The wheels of the trolley fit both I-Beams and H-Beams
- Trolley wheels are parkerized for corrosion resistance
- High quality closed bearings provide smooth traversing
- With Anti-Drop plates



Scan for Webpage,
User & Parts Manual



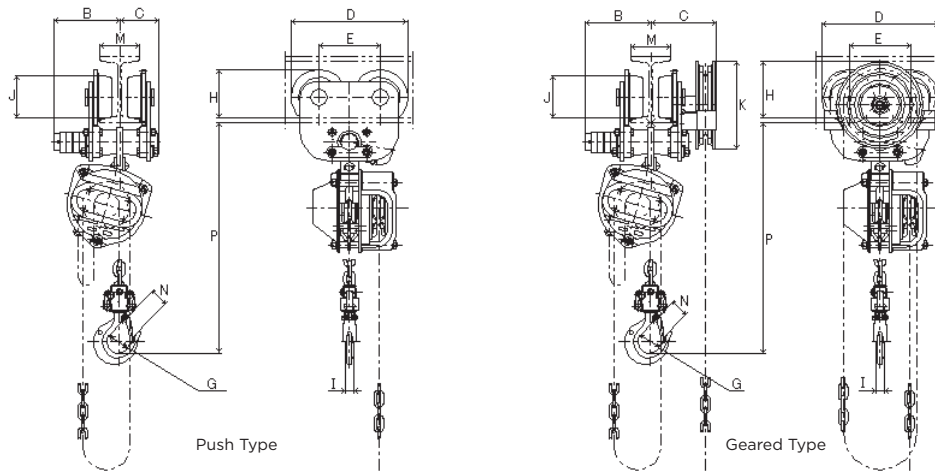

Above schematics are reference only, they are not accurate portrayals for all capacities.
Reference pages 3 and 89 for complete hoist & trolley information.

SPECIFICATIONS - ELEPHANT INTEGRAL LUG MOUNT TROLLEY HOISTS, PUSH & GEARED

Capacity (mt)	Product Code	Std. Lift (ft)	Beam Width (in)	Min. Beam Radius (ft)	Combined Headroom (in)
0.5	HP(HG)100-0.5	10	2.3 - 5.11	2.95	11.7
1	HP(HG)100-1		2.3 - 5.11	3.61	12.5
1.6	HP(HG)100-1.6		2.7 - 6.1	3.93	14.5
2	HP(HG)100-2		2.7 - 6.1	3.93	15.8
3.1	HP(HG)100-3.1		3.5 - 6.2	5.58	20.5
5	HP(HG)100-5		3.54 - 7.08	7.55	24.8
7.5	HP(HG)100-7.5		4.92 - 7.48	9.84	28.5
10	HP(HG)100-10		4.92 - 7.48	9.84	31.4

DIMENSIONS (IN) - ELEPHANT INTEGRAL LUG MOUNT TROLLEY HOISTS, PUSH TYPE

Capacity (t)	P	B	C	D	E	G	H	I	J	N
0.5	11.7	3.9	3.9	7.5	3.9	1.4	3.4	0.5	2.7	1.0
1	12.5	3.9	3.8	8.7	4.5	1.6	3.9	0.6	3.1	1.1
1.6	14.5	4.6	4.6	10.1	5.3	1.8	4.6	0.7	3.8	1.3
2	15.8	4.6	4.6	10.1	5.3	2.0	4.6	0.8	3.8	1.4
3.1	20.5	4.6	4.8	11.3	5.9	2.3	5.3	1.0	4.5	1.7
5	24.8	5.5	5.8	12.8	6.6	2.7	6.0	1.3	4.9	2.0
7.5	28.5	6.9	6.9	17.0	8.6	8.6	8.3	1.8	6.2	2.5
10	31.4	6.9	6.9	17.0	8.6	8.6	8.3	1.8	6.2	2.5

DIMENSIONS (IN) - ELEPHANT INTEGRAL LUG MOUNT TROLLEY HOISTS, GEARED TYPE

Capacity (t)	P	B	C	D	E	G	H	I	J	K	N
0.5	11.7	5	5.6	7.5	3.9	1.4	3.7	0.5	2.7	5.3	1.0
1	12.5	5	5.8	8.7	4.5	1.6	4.5	0.6	3.1	6.4	1.1
1.6	14.5	5.6	6.3	10.1	5.3	1.8	5.6	0.7	3.8	7.7	1.3
2	15.8	5.6	6.3	10.1	5.3	2.0	5.6	0.8	3.8	7.7	1.4
3.1	20.5	5.7	6.3	11.3	5.9	2.3	5.8	1.0	4.5	7.7	1.7
5	24.8	6.5	7.5	12.8	6.6	2.7	6.4	1.3	4.9	8.3	2.2
7.5	28.5	7.4	12.0	17.0	8.6	3.3	8.9	1.8	6.2	9.8	2.9
10	31.4	7.4	12.1	17.0	8.6	3.3	8.9	1.8	6.2	9.8	2.9

- 1) Dimension B and C are applicable when beam width is max.
- 2) Dimension H is applicable when beam thickness is max.
- 3) For Dimension M, please check the beam width on the specifications.
- 4) Dimension N is applicable when safety latch is opened.
- 5) Contact the factory for wide beam applications

