



EX H100 SPARK RESISTANT SERIES, HOOK MOUNT

- 0.5t through 20t Capacity
- Hand chain hoists, push & geared trolleys
- II 2 GD c II B T105 °C
- Adheres to the Council Directive and Standards in the EU for explosion proof manual chain hoists.
94/9/EC : ATEX EN1127-1 :2008,
EN13463-1 : 2009, EN13463-5 : 2003

Note:

It is the user's responsibility to properly identify which spark resistant classification is required for their application, not the hoist manufacturer or distributor.



Scan for Webpage,
User & Parts Manual



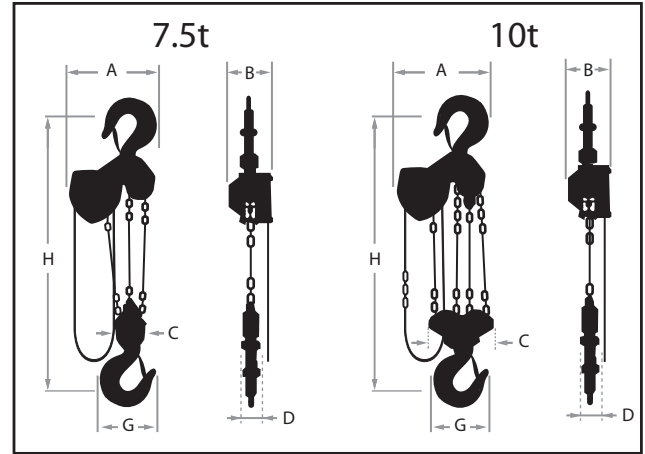
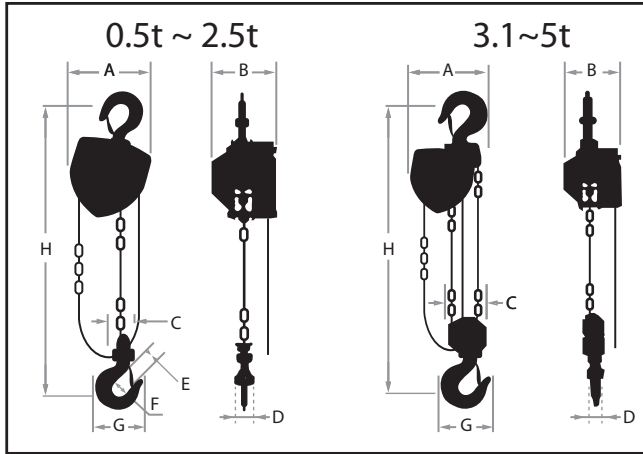

SPECIFICATIONS - EX H100 SPARK RESISTANT SERIES, HOOK MOUNT

Model	Max working load (lbs)	Max working load (mt)	Standard Lift (ft)	Manufacturer's Test Load	Headroom (in) "H"	Headroom (in) Lug Mount to Elephant P or G Trolley	Hand Effort to Lift Full Working Load (lbf)	Load Chain		Hand Chain	Net Weight (lbs)
								Dia. X Pitch (mm)	No. of Falls	Dia. X Pitch (mm)	
EX-H100-0.5	1100	0.5	10	150% x Max. working load	10.83	11.7	59.5	5 x 15	1	5 x 23.5	22
EX-H100-1	2200	1.0	10		11.81	12.5	69.5	6.3 x 19			27
EX-H100-1.6	3500	1.6	10		13.19	14.5	91.5	7.1 x 21			35
EX-H100-2	4400	2.0	10		14.77	15.8	88.2	8 x 24			46
EX-H100-2.5	5500	2.5	10		16.14	18.0	89.3	9 x 27			58
EX-H100-3.1	6800	3.1	10		20.87	20.5	104.7	7.1 x 21			53
EX-H100-5	11000	5.0	10	125% x Max. working load	24.1	24.8	105.8	9 x 27	2	87	
EX-H100-7.5	16500	7.5	10		29.53	28.5	115.7	9 x 27	3	154	
EX-H100-10	22000	10.0	10		30.52	31.4	115.7	9 x 27	4	182	

DIMENSIONS (IN.) - EX H100 SPARK RESISTANT SERIES, HOOK MOUNT

Capacity (lbs)	A	B	C	D	E	F	G	H
1100	5.5	6.1	2.3	1.3	1.1	1.4	2.7	10.83
2200	6.3	6.3	2.5	1.4	1.2	1.7	3.5	11.81
3500	7.2	6.6	2.6	1.5	1.4	1.9	4.1	13.19
4400	8.5	7.2	2.6	1.6	1.5	2.1	4.5	14.77
5500	9.2	7.5	2.8	1.7	1.6	2.2	5	16.14
6800	9.1	6.6	4.4	2.5	1.8	2.4	5.5	20.87
11000	11.1	7.5	6.6	3.1	2.1	2.8	6.4	24.61
16500	14.6	7.5	5.8	3.2	2.8	3.4	9	29.53
22000	15.2	7.5	11.8	3.9	2.8	3.4	9	30.52

