

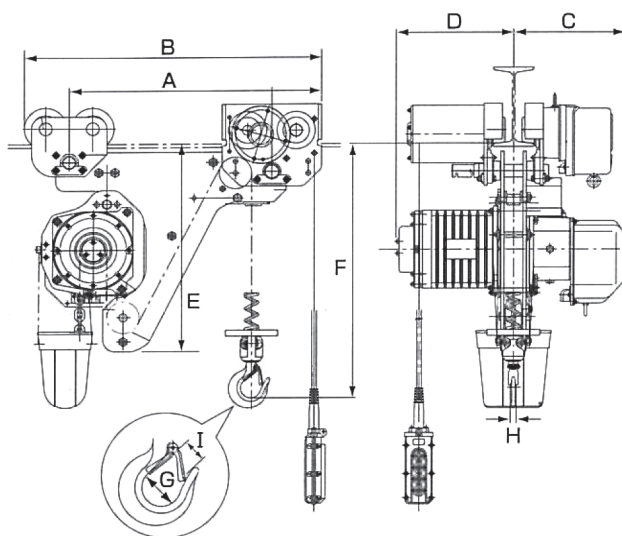

SDAM, SDBM SERIES LOW HEADROOM ELECTRIC CHAIN HOIST



Scan for Webpage,
User & Parts Manual



SPECIFICATIONS - SDAM SINGLE SPEED

Model	Capacity metric ton	Test Load metric ton	Standard Lift (ft)	Dia. of Load Chain (mm) x Falls	Lifting Motor Output (H.P.)	Traversing Motor Output (H.P.)	Lifting Spd ft per min (60Hz)	Traversing Spd ft per min (60Hz)	Headroom (in)	I Beam Width (in)
SDAM-0.25	0.25	0.312	10	6.3x1	1.22	0.54	28	78.5	14.37	Manufactured to Specification
SDAM-0.5	0.5	0.625	10	6.3x1	1.22		18.5		14.37	
SDAM-1W	1	1.125	10	6.3x2	1.22		14		18.7	
SDAM-1S	1	1.125	10	7.1x1	1.5		18		16.53	
SDAM-1.5	1.5	1.88	10	9.5x1	4.62		21.5		18.89	
SDAM-2W	2	2.5	10	7.1x2	2.31		13		20.07	
SDAM-2S	2	2.5	10	11.2x1	4.62		21		20.47	
SDAM-2.5	2.5	3.13	10	11.2x1	3.4	1.02	14	22.04		
SDAM-3	3	3.75	10	9.5x2	4.62		17	25.19		
SDAM-5	5	6.25	10	11.2x2	4.62		10.5	28.74		
SDAM-7.5	7.5	9.375	Contact Factory						31.49	
SDAM-10	10	12.5							31.49	
SDAM-15	15	18.75							38.58	
SDAM-20	20	25							41.73	

SPECIFICATIONS - SDBM DOUBLE SPEED

Model	Capacity metric ton	Test Load metric ton	Standard Lift (ft)	Dia. of Load Chain (mm) x Falls	Lifting Motor Output (H.P.)	Traversing Motor Output (H.P.)	Lifting Spd ft per min (60Hz)	Traversing Spd ft per min (60Hz)	Headroom (in)	I Beam Width (in)
SDBM-0.25	0.25	0.312	10	6.3x1	1.22 : 0.41	0.54 : 0.14	28 : 9	78.5 : 39	14.37	Manufactured to Specification
SDBM-0.5	0.5	0.625	10	6.3x1	1.22 : 0.41		28 : 9		14.37	
SDBM-1W	1	1.125	10	6.3x2	1.22 : 0.41		14 : 4.5		18.7	
SDBM-1S	1	1.125	10	7.1x1	2.31 : 0.77		27 : 9		16.53	
SDBM-1.5	1.5	1.88	10	9.5x1	4.62 : 1.55		22 : 7.5		18.89	
SDBM-2W	2	2.5	10	7.1x2	2.31 : 0.77		13 : 4		20.07	
SDBM-2S	2	2.5	10	11.2x1	4.62 : 1.55		21 : 7		20.47	
SDBM-2.5	2.5	3.13	10	11.2x1	4.62 : 1.55	1.02 : 0.14	21 : 7	22.04		
SDBM-3	3	3.75	10	9.5x2	4.62 : 1.55		17 : 5.5	25.19		
SDBM-5	5	6.25	10	11.2x2	4.62 : 1.55		10.5 : 3	28.74		
SDBM-7.5	7.5	9.375	Contact Factory						31.49	
SDBM-10	10	12.5							31.49	
SDBM-15	15	18.75							38.58	
SDBM-20	20	25							41.73	

DIMENSIONS (IN.) - SDAM/SDBM

Model	A	B	C	D	E	F	G	H	I	Unit Weight (lbs) with 10' Lift
SDAM-0.25	18.50	27.72	10.28	10.51	19.02	14.37	1.69	0.55	1.02	243
SDAM-0.5	18.50	27.72	10.28	11.93	19.02	14.37	1.69	0.55	1.02	243
SDAM-1W	18.50	27.72	10.28	10.51	19.02	18.70	1.97	0.59	1.22	280
SDAM-1S	19.69	28.90	10.75	12.60	20.63	16.54	1.97	0.59	1.22	309
SDAM-1.5	24.02	35.51	12.28	13.43	24.13	18.90	2.56	1.02	1.50	562
SDAM-2W	20.08	31.57	10.75	11.42	21.18	20.08	2.56	1.02	1.50	375
SDAM-2S	24.80	36.30	12.28	13.43	25.00	20.47	2.56	1.02	1.50	584
SDAM-2.5	24.80	36.69	12.28	14.61	25.16	22.05	2.56	1.02	1.50	595
SDAM-3	24.02	35.91	12.28	13.43	24.29	25.20	2.36	1.26	1.73	617
SDAM-5	26.38	39.45	12.28	13.43	26.57	28.74	2.76	1.38	1.89	750
SDBM-0.25	18.50	27.72	11.30	11.93	19.02	14.37	1.69	0.55	1.02	278
SDBM-0.5	18.50	27.72	11.30	11.93	19.02	14.37	1.69	0.55	1.02	278
SDBM-1W	18.50	27.72	11.30	11.93	19.02	18.70	1.97	0.59	1.22	322
SDBM-1S	19.69	28.90	11.69	12.60	20.63	16.54	1.97	0.59	1.22	353
SDBM-1.5	24.02	35.51	13.54	14.61	24.13	18.90	2.56	1.02	1.50	609
SDBM-2W	20.08	35.51	11.69	12.60	21.18	20.08	2.56	1.02	1.50	419
SDBM-2S	24.80	36.30	13.54	14.61	25.00	20.47	2.56	1.02	1.50	628
SDBM-2.5	24.80	36.69	13.54	14.61	25.16	22.05	2.56	1.02	1.50	633
SDBM-3	24.02	35.91	13.54	14.61	24.29	25.20	2.36	1.26	1.73	655
SDBM-5	26.38	39.45	13.54	14.61	26.57	28.74	2.76	1.38	1.89	787

