



BETA COMPACT ELECTRIC CHAIN HOIST

- 125kg & 200kg
- 1 Phase 115V
- Unit weight with standard lift is 10 lbs
- 11" headroom
- Ideal for carrying in tool boxes
- Overload protection device
- Overwind protection
- Plastic chain container
- Ratings JIS / ISO 1AM, FEM M4, ASME H2, Hoist protection is IP54, Pendant is IP65 NEMA 4X



Scan for Webpage,
User & Parts Manual

SPECIFICATIONS - BETA COMPACT ELEC. CHAIN HOIST

Model	BS-012	BS-020
Capacity (kg)	125	200
Capacity (lbs)	275 lb	440 lb
Motor output (H.P.)	0.25	
Short time rating (min.)	25	
%ED	30%	
Maximum starting frequency (times/h)	180	
Voltage	Single phase 115V	
Ampere (A)	4	
Lifting speed (ft / min.)	21	12.5
Headroom(in)	11	
Load chain (Dia. X Pitch)	3mm x 9mm	
Power cable (ft)	9.8 ft (1.25mm ² x 3cores) with plug	
Weight	16.5 lb (10 ft lift) : 17lb (20 ft lift)	

* Maximum lift is 32 ft

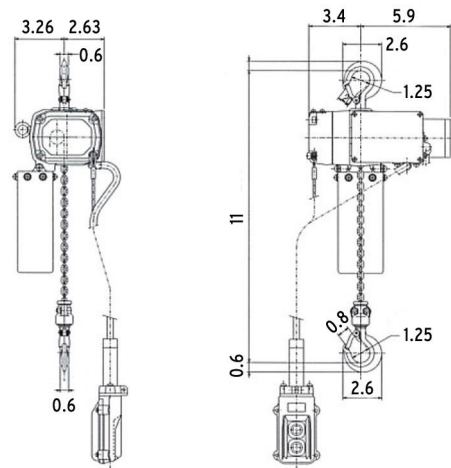

Above schematic measured in inches

