

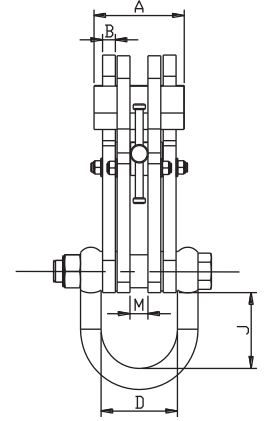

Scan for Webpage,
User & Parts Manual

JUMBO BEAM CLAMP

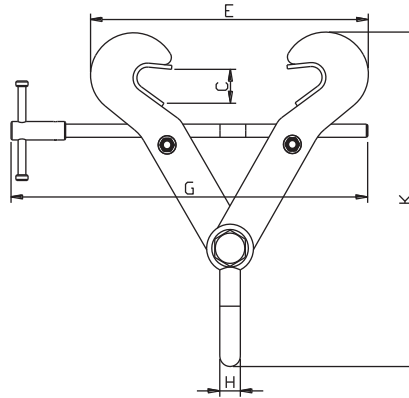

The Jumbo Beam Clamp is a great option for rigging applications. This clamp line features a wide jaw opening for wide flange beams used throughout industry. The JBC's clamp screw assembly is also zinc plated. This clamp series features metric capacities that range from 3, 5, 6, 10, 16, and 32 tons.

SPECIFICATIONS & DIMENSIONS - JUMBO BEAM CLAMP																
Type	S.W.L. (lbs.)	S.W.L. US Ton	Beam Width (inch)	Max. Plate Thickness (in.)	Dimensions (inch)										Jaw Type	Weight (lbs)
					A	B	C	D	E max	G	H	J	K min			
JBC-3A	6600	3.3	3.00-7.48	0.55	5.12	0.55	1.06	4.21	10.71	10.87	0.79	3.35	10.00	Fixed	18	
JBC-5A	11000	5.5	6.00-12.00	1.29	5.50	0.55	1.81	4.80	17.72	16.10	0.98	3.90	12.56	Fixed	33	
JBC-5B	11000	5.5	3.00-7.48	1.29	5.50	0.55	1.81	4.80	13.39	13.35	0.98	3.90	12.99	Fixed	22	
JBC-6	13200	6.6	8.00-18.00	1.29	6.60	0.55	2.17	4.57	23.62	22.01	0.98	3.90	16.46	Fixed	42	
JBC-10	22000	11	8.00-18.00	1.29	5.51	0.79	2.17	4.69	23.62	22.01	1.26	3.90	16.46	Fixed	62	
JBC-16A	35000	17.6	16.00-24.00	2.20	6.89	0.79	3.00	5.12	24.02	31.89	1.77	7.87	25.75	Fixed	135	
JBC-16B	35000	17.6	8.00-18.00	2.20	6.89	0.79	3.00	5.12	17.99	25.98	1.77	7.87	22.60	Fixed	119	
JBC-32	48000	24	12.00-30.00	2.20	17.87	0.78	3.20	4.12	39.40	42.83	2.61	10.63	31.81	Fixed		

SIDE LOAD ACROSS BEAM ONLY - CLAMP MUST BE FLUSH ON BEAM WITH SHACKLE AT A ZERO DEGREE DOWNWARD FACING ANGLE					
Chart only applies to overhead beam attachment. If clamps are being used to lift beams, this information is not applicable. Table applies to the listed models only. Stress calculations should be performed by the end user's engineering dep.	Reduction in working load limit when side loads are applied				
	Angle from vertical (degree)	0	0 to 15	15 to 30	30 to 45
	Reduction Factor	NIL	17.00%	34.00%	50.00%
	Model	WLL	WLL	WLL	WLL
	JBC-3A	3 ton	2.5 ton	2 ton	1.5 ton
	JBC-5A	5 ton	4.1 ton	3.3 ton	2.5 ton
JBC-6	6 ton	5 ton	4 ton	3 ton	
JBC-10	10 ton	8.3 ton	6.6 ton	5 ton	
JBC-16B JBC-16A	16 ton	13.2 ton	10.5 ton	8 ton	
JBC-32	32 ton	26.56 ton	21.12 ton	16 ton	

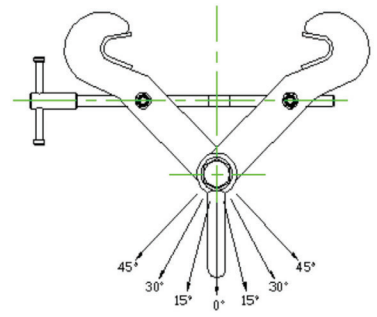

* Warning: Clamps must be installed properly and fully tightened
 * Always contact the manufacturer when in doubt

