

AIR CHAIN HOIST WITH MOTORIZED TROLLEY



Scan for Webpage, User & Parts Manual

- Motorized trolleys available for the ATSI & Rigger Series
- For hoist capacities greater than 20 ton, see the Monorail Style Units
- Air motor has a polished stainless steel cylinder
- Anti-tip and anti-drop devices
- Manufactured with high quality steel components, allowing for a compact design
- Available with spark resistant features
- Available with marine paint finish

SPECIFICATIONS - ATS MOTORIZED TROLLEYS - 0.5 ton - 5ton

Lifting capacity	Ton	0.5	1	2	3	4.2	5
Model		ATSI-M-0.5	ATSI-M-1	ATSI-M-2	ATSI-M-3	ATSI-M-4.2	ATSI-M-5
Number of falls of chain		1	1	1	1	1	1
Weight with 10ft lift	lbs	156.8	163.5	177.0	246.4	358.4	380.8
Chain weight per ft lift	lbs	0.73	0.73	1.18	1.8	2.6	3.8
Chain size	mm	7x21	7x21	9x27	13x36	13x36	16x45
Working air pressure	bar	5-7	5-7	5-7	5-7	5-7	5-7
Air consumption @ full load	CFM	75	75	75	110	110	110
Air hose connection	BSP	3/4"	3/4"	3/4"	3/4"	3/4"	3/4"
Lifting speed @ full load	ft/min	52	16.5	15	8.9	7.5	5.9
Lifting speed @ no load	ft/min	98	24	28	13.1	10.2	9.8
Lowering speed @ full load	ft/min	82	19	30	13.8	9.2	11.5
Trolley Travelling Speed	ft/min	39.4	39.4	39.4	39.4	32.8	32.8
Noise level	dBA @3ft	84	84	84	84	84	84

* Increased speed conversion kits are available



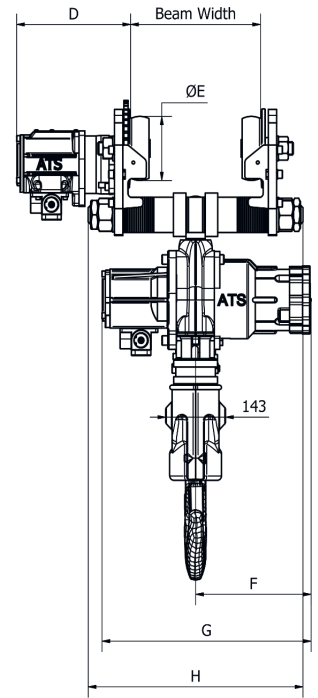
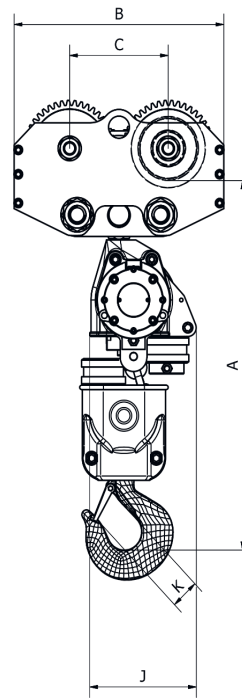
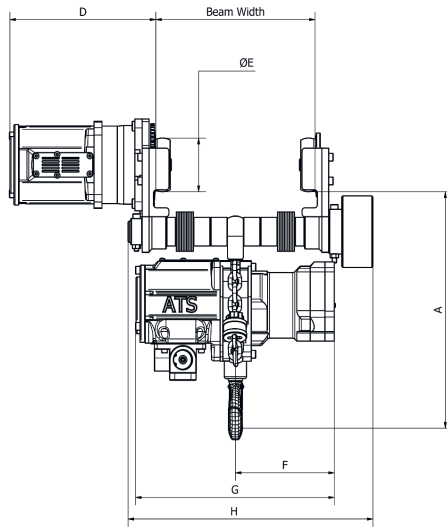
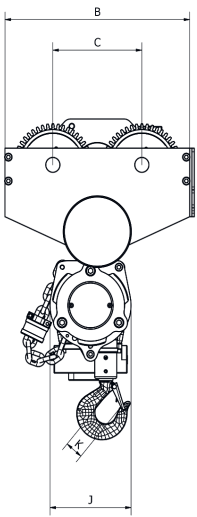

*Schematics for reference only



*Schematics for reference only

DIMENSIONS (in.) - ATS MOTORIZED TROLLEYS - 0.5ton - 5ton						
Lifting Capacity (t)	0.5	1.0	2.0	3.0	4.2	5.0
Beam width range	2.55-11.02			3.93-8.26		
A min. headroom LUG	15.6	15.6	15.8	22.8	24.2	24.4
A min. headroom HOOK	19.6	19.6	20.2	29.9	33.0	33.0
B	12.8	12.8	12.8	13.2	14.6	14.6
C	6.2	6.2	6.2	6.3	7.0	7.0
D	10.1	10.1	10.1	10.3	10.8	10.8
E	3.5	3.5	3.5	3.6	4.4	4.4
F	4.0	6.9	8.0	9.6	10.9	11.1
G	10.9	13.8	15.1	18.3	19.6	20.0
H	13.8	13.8	13.8	13.0	14.8	14.8
J	5.6	5.6	5.6	9.3	9.3	12.2
K	0.9	0.9	0.9	1.2	1.2	1.6



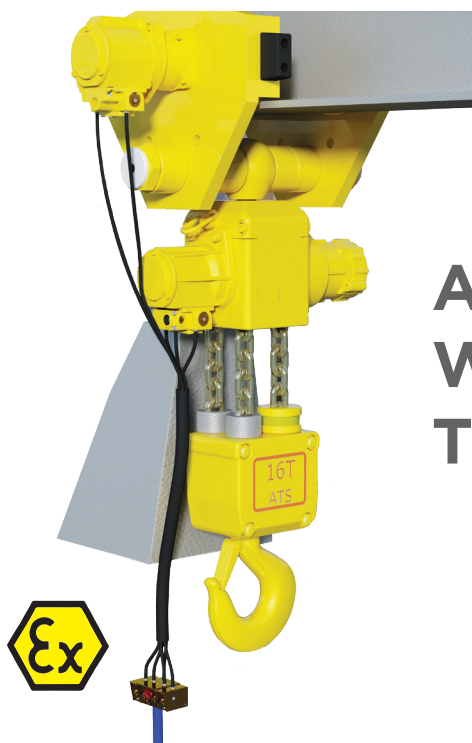

AIR CHAIN HOIST WITH MOTORIZED TROLLEY

SPECIFICATIONS - ATS MOTORIZED TROLLEYS - 6ton - 20ton

Lifting capacity	Ton	6	10	16	18	20
Model		ATSI-M-6	ATSI-M-10	ATSI-M-16	ATSI-M-18	ATSI-M-20
Number of falls of chain		2	2	4	3	4
Weight with 10ft lift	lbs	425.6	604.8	1299.1	1411.1	1735.9
Chain weight per ft lift	lbs	3.7	7.7	10.2	11.5	15.3
Chain size	mm	13x36	16x45	13x36	16x45	16x45
Working air pressure	bar	5-7	5-7	5-7	5-7	5-7
Air consumption @ full load	CFM	110	110	110	110	110
Air hose connection	BSP	3/4"	3/4"	3/4"	3/4"	3/4"
Lifting speed @ full load	ft/min	4.4	3.0	2.0	3.0	2.1
Lifting speed @ no load	ft/min	6.6	4.9	2.6	4.3	4.6
Lowering speed @ full load	ft/min	6.9	5.7	2.3	4.3	5.9
Trolley Travelling Speed	ft/min	32.8	26.2	26.2	26.2	26.2
Noise level	dBA @3ft	84	84	84	84	84

* Increased speed conversion kits are available



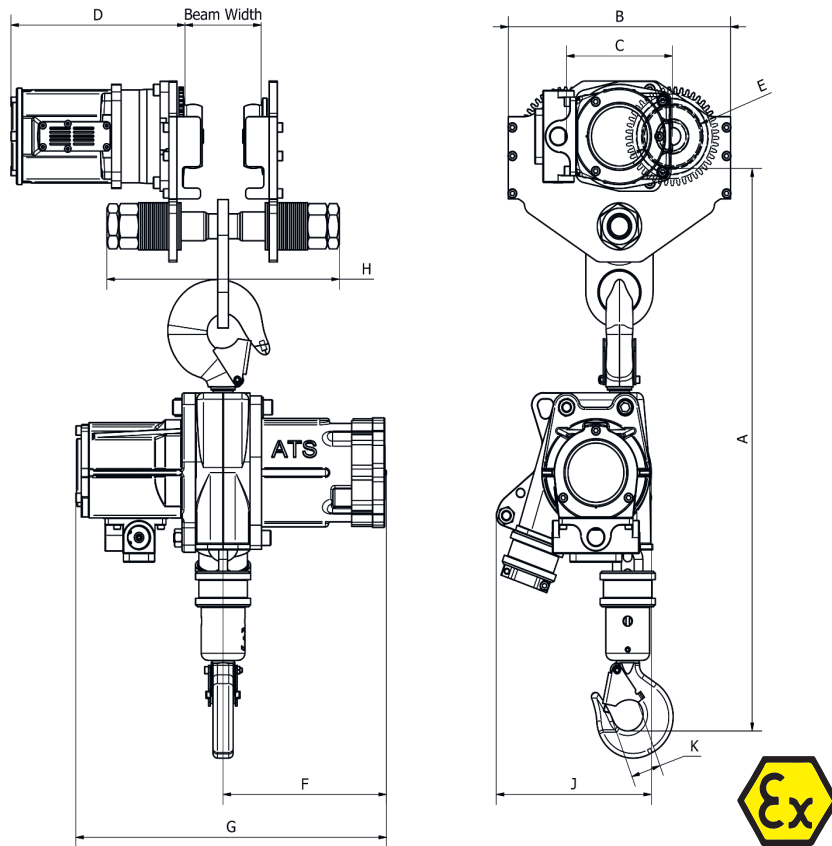

*Schematics for reference only

DIMENSIONS (in.) - ATS MOTORIZED TROLLEYS - 6ton - 20ton					
Lifting Capacity (t)	6.0	10.0	16.0	18.0	20.0
Beam width range	4.3-8.3	6.7-12.2	6.9-13.0		
A min. headroom LUG	29.3	30.4	34.3	41.9	41.9
A min. headroom HOOK	36.1	38.2	42.9	50.0	50.0
B	14.6	20.0	23.6	24.0	24.0
C	7.0	9.4	9.3	11.4	11.4
D	10.8	10.9	10.9	11.3	11.3
E	4.4	5.8	5.7	7.9	7.9
F	9.6	11.1	12.6	13.6	12.9
G	18.3	20.0	23.7	23.9	24.3
H	14.8	19.6	23.2	21.7	21.7
J	9.3	12.2	11.8	13.0	13.0
K	1.6	2.1	2.3	3.1	3.1

