



# ATS COMPACT SERIES AIR CHAIN HOIST 0.25t ~ 2 ton



Scan for Webpage,  
User & Parts Manual

SPECIFICATIONS - ATSC COMPACT SERIES AIR CHAIN HOIST - 0.25t - 2 ton					
Lifting capacity	Ton	0.25	0.5	1	2
Model		ATSC-025	ATSC-05	ATSC-1	ATSC-2
Number of falls of chain		1	1	1	2
Weight with 10ft lift	lbs.	43.7	43.7	43.7	53.8
Chain weight per ft lift	lbs.	2.4	2.4	2.4	4.8
Chain size	mm	7x21	7x21	7x21	7x21
Working air pressure	bar	5-7	5-7	5-7	5-7
Air consumption @ full load	CFM	60	60	60	60
Air hose connection	BSP	1/2"	1/2"	1/2"	1/2"
Lifting speed @ full load	ft/min	30.8	28.8	21.7	13.1
Lifting speed @ no load	ft/min	32.81	32.81	32.8	19.0
Lowering speed @ full load	ft/min	40.08	42.7	42.7	20.3
Noise level	dBA @3ft	84	84	84	84



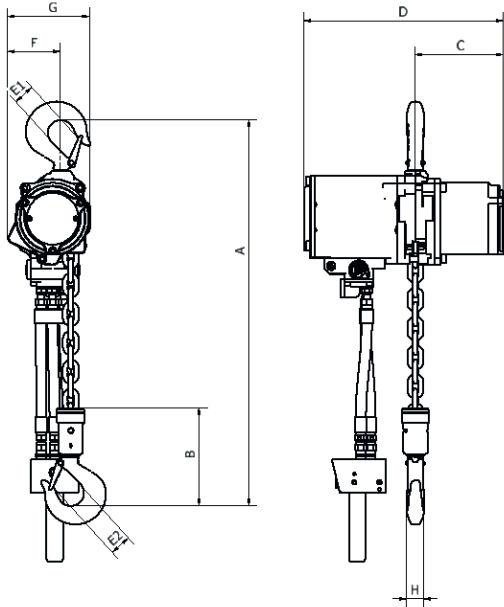

\*Schematics are for reference only

**Features:**

- Rust free & replaceable stainless steel cylinder
- 100% Duty cycle
- Robust epicycle gearbox (grease filled and sealed)
- Choice pilot pendant with E-Stop or direct pendant control - Variable speed
- Urethane yielding buffers for upper and lower limit stops
- Aluminium and SG Iron housings
- Internal silencing
- High grade carbon steel swivel hooks with safety catches
- Corrosion resistant load chain made to EN818-7 standard - 5:1 Design factor of safety
- Automatic self-adjusting multi disc brake 125% WLL
- Tried and tested delta P design load limiting device set 125% WLL
- Spark resistant (Atex Zone 2)

**Options:**

- Marine spec - Nickel coated and marine paint
- Corrosion resistance: stainless steel hooks and chain, special paints
- Chain containers
- Plain, geared and motorized trolleys

DIMENSIONS (in.) - ATSC COMPACT SERIES AIR CHAIN HOIST - 0.25t - 2 ton				
Type	0.25t	0.5t	1t	2t
A Min. Headroom	12.1	12.1	12.1	15.6
B	5.6	5.6	5.6	5.6
C	5.0	5.0	5.0	5.0
D	11.4	11.4	11.4	11.4
E1	0.9	0.9	0.9	0.9
E2	0.9	0.9	0.9	0.9
G Max Width	4.7	4.7	4.7	5.6
H Hook Width	0.9	0.9	0.9	0.9

