

RIGGER SERIES AIR CHAIN HOIST

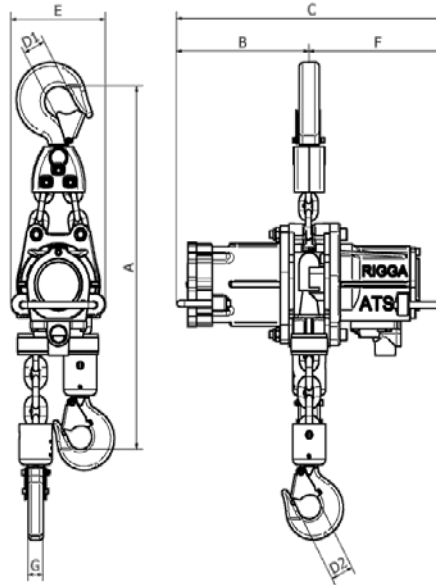

SPECIFICATIONS - ATS RIGGER CHAIN HOIST - 1ton - 8ton								
Lifting capacity	t	1/1	2/2	3/3	3/6	4,2/4,2	5/5	4,2/8,4
Number of falls of chain		1/1	1/1	1/1	1/2	1/1	1/1	1/2
Weight with R-Control	lbs.	81.6	81.6	125.7	178.6	156.5	183.0	187.4
Weight with D-Control	lbs.	92.6	103.6	131.2	185.2	163.1	176.4	194.0
Chain size	mm	9x27	9x27	11,2x34	11,2x35	13x36	16x45	13x36
Chain weight per m lift	lbs./ft	1.2	1.2	1.8	1.8	2.6	3.9	2.6
Working air pressure	bar	4						
Air consumption @ full load	CFM	61.8	61.8	61.8	61.8	61.8	61.8	61.8
Air hose connection	BSP	1"						
Lifting speed @ full load	ft/min	16.4	9.8	14.8	14.8/7.4	10.5	8.5	5.2
Lifting speed @ no load	ft/min	55.8	32.8	19.0	16.4/8.2	13.1	10.5	143904.2
Lowering speed @ full load	ft/min	65.6	42.7	20.3	24.6/12.5	14.8	8.5	7.4
Standard lift	ft	10						
Length of control for Standard Lift	ft	6.5						
Noise level	dBA@3ft	84						

DIM. (in.) - ATS RIGGER - 1ton - 8ton							
Type	1 ton	2 ton	3 ton	4,2 ton	5 ton	6 ton	8 ton
A min .headroom	12.8	12.8	24.0	20.6	28.7	2.6	28.7
B	4.7	4.7	8.9	8.9	12.6	13.1	13.1
C	8.0	8.0	9.2	9.2	10.5	9.2	10.5
D	15.0	15.0	18.9	18.9	20.5	18.9	20.5
E1	1.3	1.3	1.6	1.6	1.7	1.6	1.7
E2	1.3	1.3	1.6	1.6	1.7	1.6	1.7
G max.width	5.7	5.7	9.4	9.4	13.4	9.4	13.4
H	7.1	7.1	9.7	9.7	10.0	9.7	10.0
I	8.3	8.3	11.8	11.8	18.9	16.7	18.9
J Hook width	0.9	0.9	1.8	1.8	2.1	1.9	2.1

* Chain containers will increase headroom

